

## **Fairey Battle - In Belgium**

### *Instructions*

**FR**

Le Fairey Battle est développé en réponse à la spécification P37/32 de 1933. Le premier vol du prototype a lieu le 10 mars 1936. Les Battle, assemblés par Fairey (1164) et par Austin Motors (1032), sont produits en version bombardier, mais aussi en appareil d'entraînement (T) et en remorqueur de cible (TT). Le Fairey Battle est largement utilisé par la RAF mais aussi par l'Australie (367), la Belgique (16), le Canada (754), l'Eire, la Grèce (11), l'Inde (2), la Nouvelle Zélande (2), l'Afrique du Sud (179), la Rhodésie (25), la Turquie (30). Il est également employé par l'Armée de l'Air polonaise au Royaume Uni. La RAF reçoit ses premiers Battle en 1937, plus de 40 squadrons utilisent l'appareil.

À la déclaration de la guerre, 10 squadrons de l'AASF prennent position en Champagne. Le 10 mai 1940, sur 32 Battle en action, 13 sont abattus par la FLAK, les autres étant endommagés. Le lendemain, les huit appareils qui bombardent les Allemands au Luxembourg sont tous abattus. Le 15 mai, les Battle passent au bombardement de nuit. En une semaine de combat, les bombardiers de l'AASF ont eu 50 % de pertes. Pendant la campagne de France, il semble que 137 Battle aient été perdus.

La RAF entreprend, à partir du 21 juillet 1940, une campagne de bombardement de nuit sur le continent. Les Sqn de Battle n°12, 142, 103 et 150 participent à ces opérations, ainsi que les Sqn polonais 300 et 301 à partir d'août, jusqu'en octobre 1940.

La Belgique achète 16 Battle construits à l'usine Fairey de Heaton Chapel, ils sont numérotés de T58 à T73. Seuls onze Battle sont disponibles lors de l'attaque allemande, leur action la plus importante a lieu le 11 mai, trois pelotons de trois Battle attaquent les ponts du Canal Albert (Veldwezelt, T73, T60, T58, Vroenhoeven T70, T64, T61, Briegden T62, T68, T71), seuls le T73, le T64 et le T71 reviennent à leur base, les autres sont abattus.

La Grèce reçoit 11 Battle codés B271 à B282, alloués au 33 MIRA. Après l'attaque italienne du 28 octobre 1940, les Battle, basés à Kouklaina, bombardent les forces ennemies, plusieurs sont perdus (B272, B276, B274). L'attaque allemande, à partir du 6 avril 1941, détruit les survivants. Les Battle britanniques, belges, polonais, grecs et sud-africains (en Afrique orientale) sont employés en combat lors de la Seconde guerre mondiale.

**Spécifications** (bombardier) : bombardier monomoteur triplace (biplace pour les Belges), moteur Merlin I, II, ou III, délivrant 880 HP au décollage. Vitesse maximum 394 km/h à 6 000 m, plafond 7 620 m, envergure 16,46 m, longueur 12,9 m. Armement offensif : 4 bombes de 250 Lb en interne sous aile, deux bombes de 250 Lb en extérieur. Armement défensif : une mitrailleuse de 7,62 cm dans l'aile droite, une mitrailleuse Vickers de 7,62 cm en arrière du cockpit.

**EN**

The 1933 Air Ministry Specification P37/32 sought a replacement for the biplane Hawker Hart then in service. Fairey's design was selected for production and named Battle. March 10, 1936 saw the prototype's maiden flight. Battles were assembled by Fairey (1,164) and Austin Motors (1,032). The majority of Battles were produced as bombers but also as trainers (T), and as target tugs (TT). Battles were flown by RAF and the air forces of Australia (367), Belgium (16), Canada (754), Eire, Greece (11), India (2), New Zealand (2), South Africa (179), Rhodesia (25), Turkey (30). Also, members of the Polish Air Force in the UK initially flew the Battle with Nos. 300, 301, 304, and 305 (Pol) Sqn, RAF. The RAF received its first Battle in 1937. More than 40 squadrons flew the type in service.

When war was declared, ten squadrons belonging to the AASF took up positions in Champagne. On May 10, 1940, the first bombing raids revealed the Battle's extreme vulnerability when 13 of 32 committed to action were shot down. The next day, eight Battles bombing the Germans in Luxembourg were all shot down. On 15 May, the Battles switched to night bombing. In one week of fighting the AASF's Bombers squadrons averaged 50% losses, and during the brief French campaign 137 Battles were lost. Beginning on the night of 21-22 July 1940, the RAF commenced a night bombing campaign on the Continent. Battle-equipped Squadron Nos. 12, 142, 103 and 150 took part in these operations, and Nos. 300 and 301 (Pol) Sqn joined the operations from 14 August, until the last action of 15/16 October 1940.

Belgium bought 16 Battles built at the Fairey factory in Heaton Chapel, UK. They were coded T58 to T73. Their most important action took place the next day when three flights of three Battles each attacked the bridges of the Albert Canal (Veldwezelt, T73, T60, T58, Vroenhoeven T70, T64, T61, Briegden T62, T68, T71). Only T73, T64, and T71 returned to base, the others were all shot down.

Greece received 11 Battles coded B271 to B282 and allocated to 33 MIRA. After the Italian attack of October 28, 1940, Kouklaina-based Battles carried out attacks against the enemy forces when several were lost (B272, B276, B274). The German attack, commencing on April 6, 1941, destroyed the surviving Battles. British, Belgian, Polish, Greek and South African (in East Africa) Battles were used in combat during WWII.

**Specifications** (bomber): single-engine, three-seater bomber (two-seater for the Belgians), Merlin I, II, or III engine, delivering 880 HP at take-off. Maximum speed 394 km/h at 6,000 m, ceiling 7,620 m, wingspan 16.46 m, length 12.9 m. Offensive armament: four 250 Lb bombs internally under wing, two 250 Lb bombs externally. Defensive armament: one 7.62 mm machine gun in the right wing, one 7.62 mm Vickers machine gun in the rear cockpit.

Tous nos remerciements aux personnes qui ont fourni des informations / Thanks to all persons who provided informations.

# Parts List

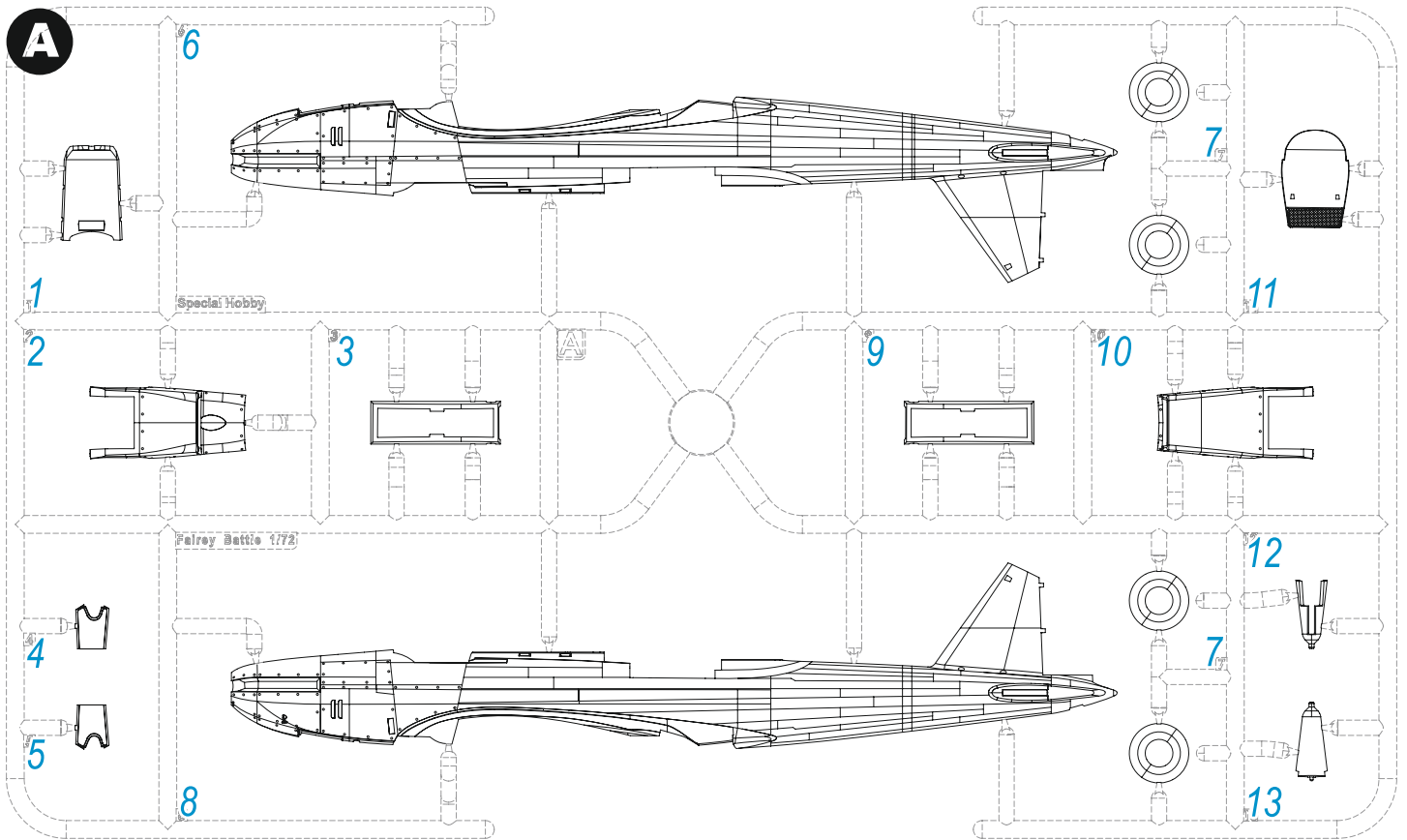

✗ = Not used

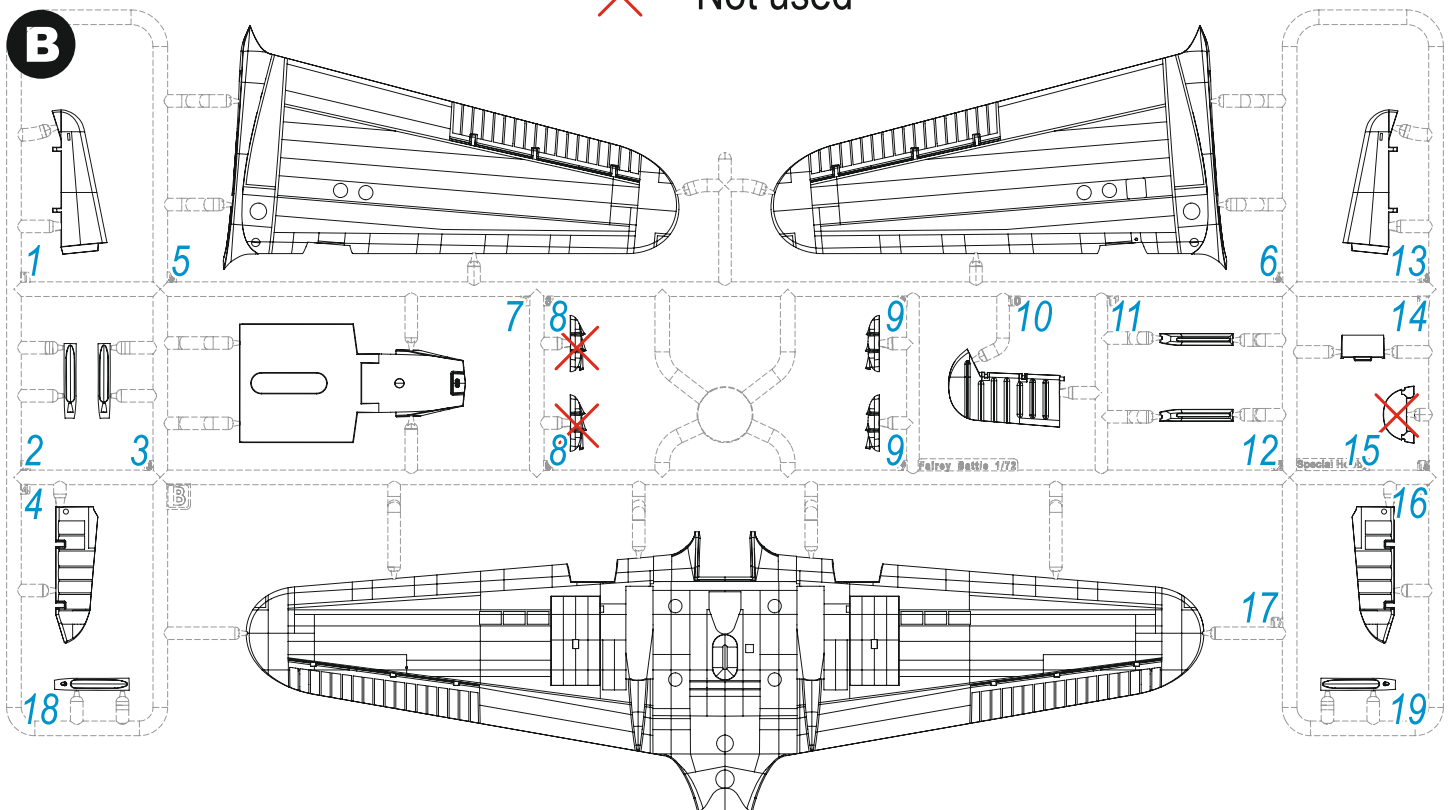

MOŽNOST VOLBY  
OPTIONAL  
NACH BELIEBEN  
OPTION



POUŽÍŤ KYANOAKRYLÁTOVÉ LEPIDLO  
INSTANT CYANOACRYLATE GLUE  
ZYANOAKRYLÁTKLEBER  
ADHÉSIF CYANOACRYLAT

## SYMBOLS



OHNOUT  
BEND  
BIEGEN  
COURBER



ZHOTOVIT NOVĚ  
SCRATCH BUILD  
FERTIGSTELLEN  
ACHEVER



ŘEZAT/VRTAT  
CUT OFF/DRILL  
ENTFERNEN  
DETACHER



NATRÍT  
COLOUR  
FARBEN  
PEINDRE

2

FR0046 Fairey Battle

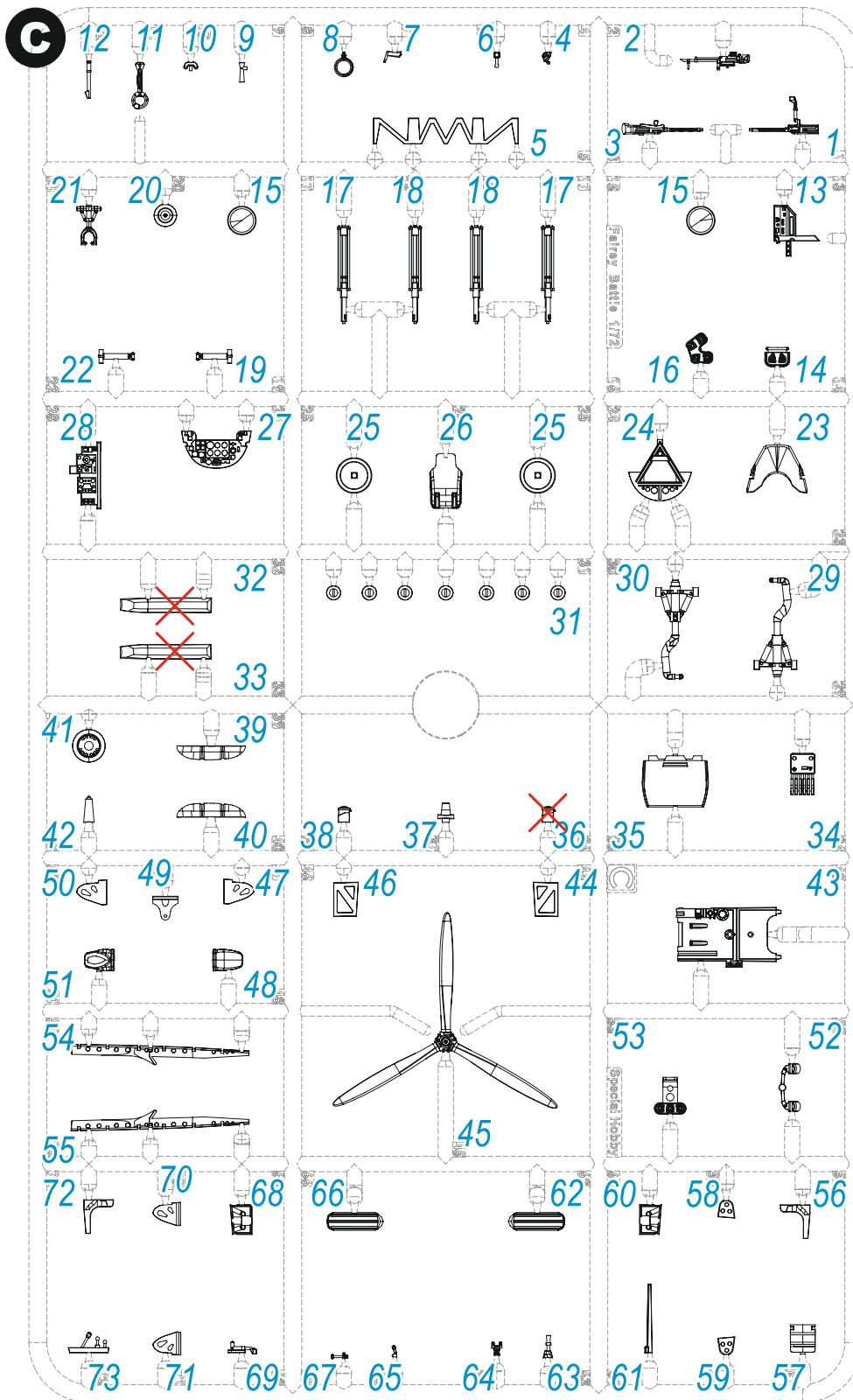

X = Not used

Clear Parts

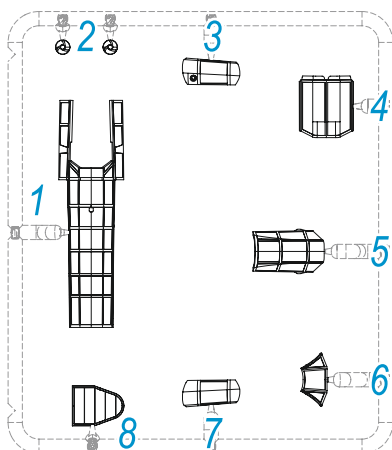

**GUNZE Colour No.**

<b>(A)</b>	Vert Gris / Grey Green (interior)	H58/C27
<b>(B)</b>	Noir / Black	H12/C33
<b>(C)</b>	Noir De Pneu / Tire Black	H77/C137
<b>(D)</b>	Alu / Aluminium	H8/C8
<b>(E)</b>	Métal Carbonisé / Burnt Iron	H76/C61
<b>(F)</b>	Fer Foncé / Dark Iron	H28/C78
<b>(G)</b>	Rouge Transparent / Clear Red	H90/C47
<b>(H)</b>	Vert Transparent / Clear Green	H94/C138
<b>(I)</b>	Cuir / Leather	H47/C41
<b>(J)</b>	Jaune / Yellow	H329/C329

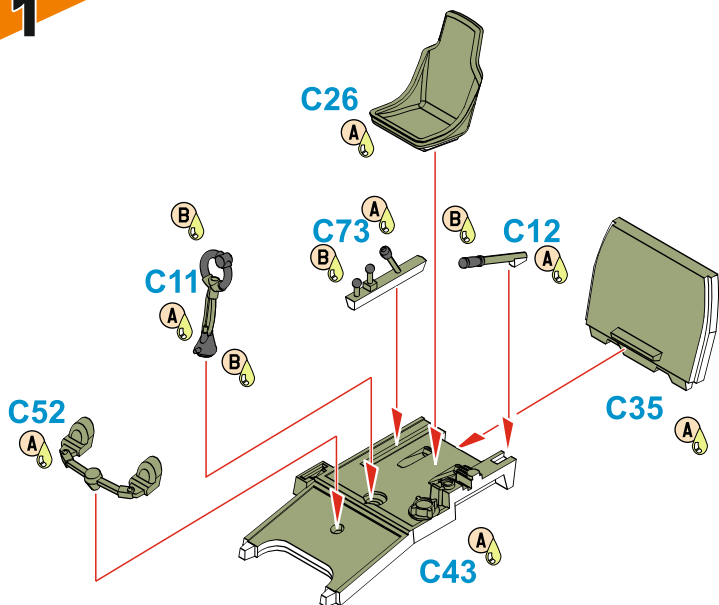
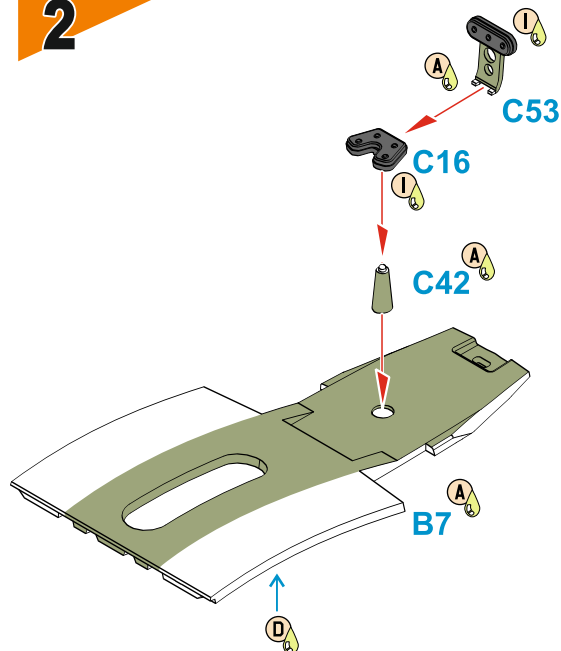
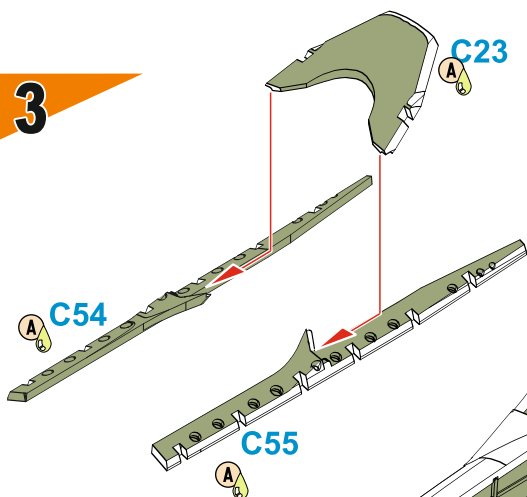
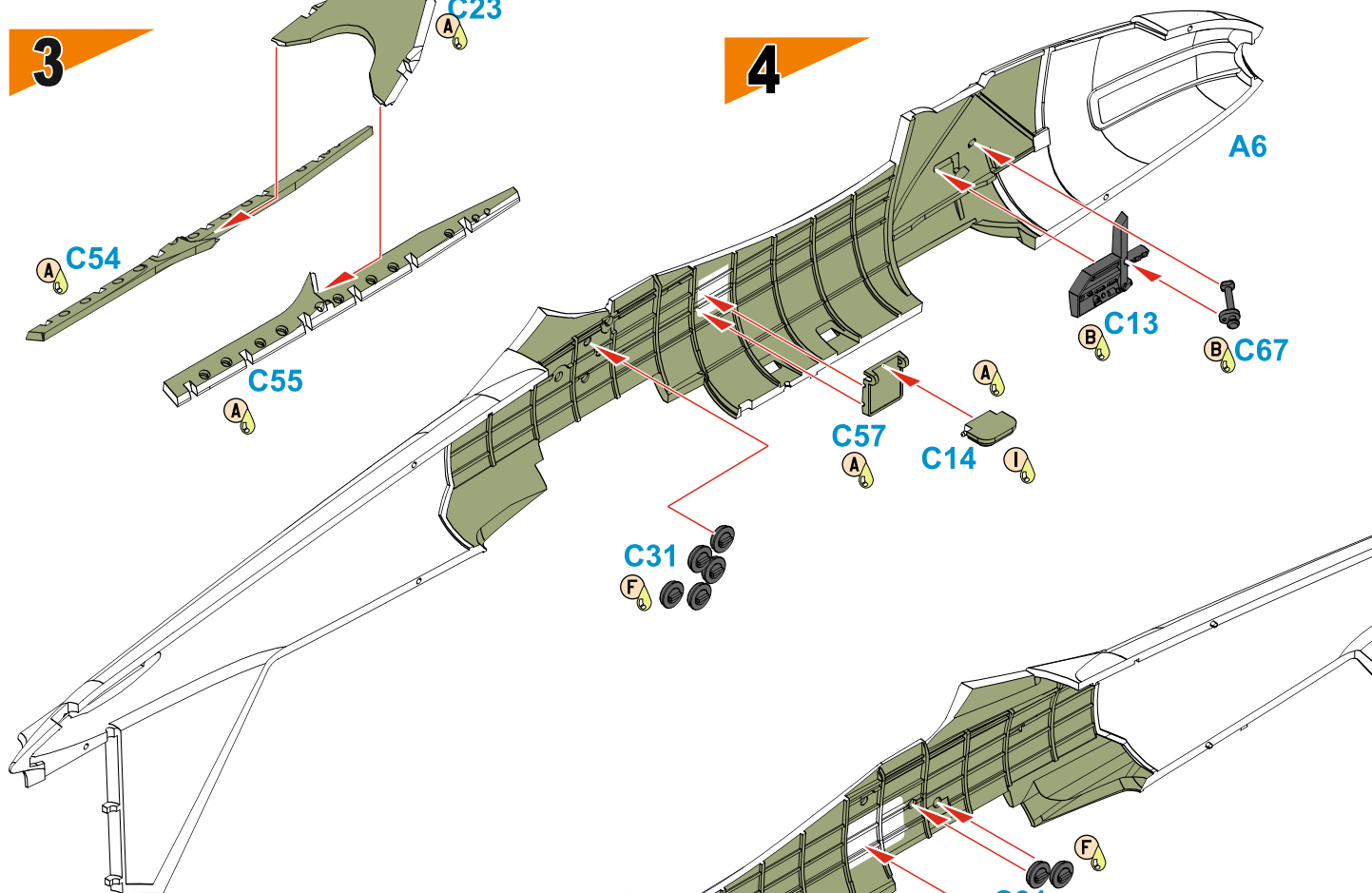
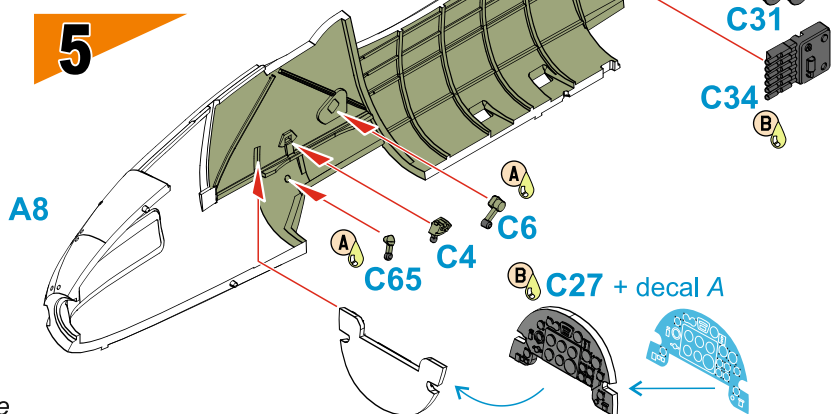
**1****2****3****4****5****4**

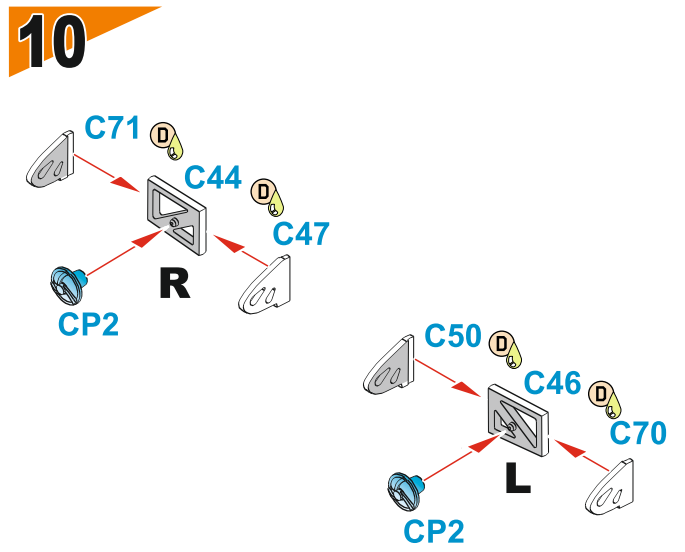
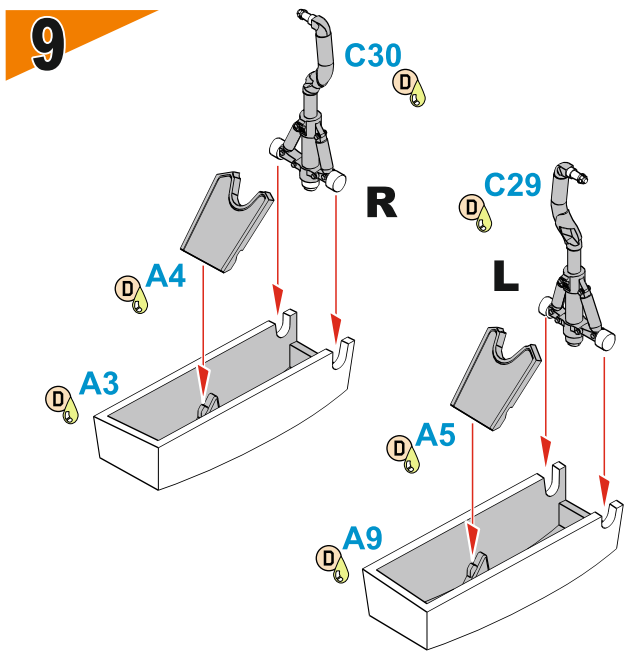
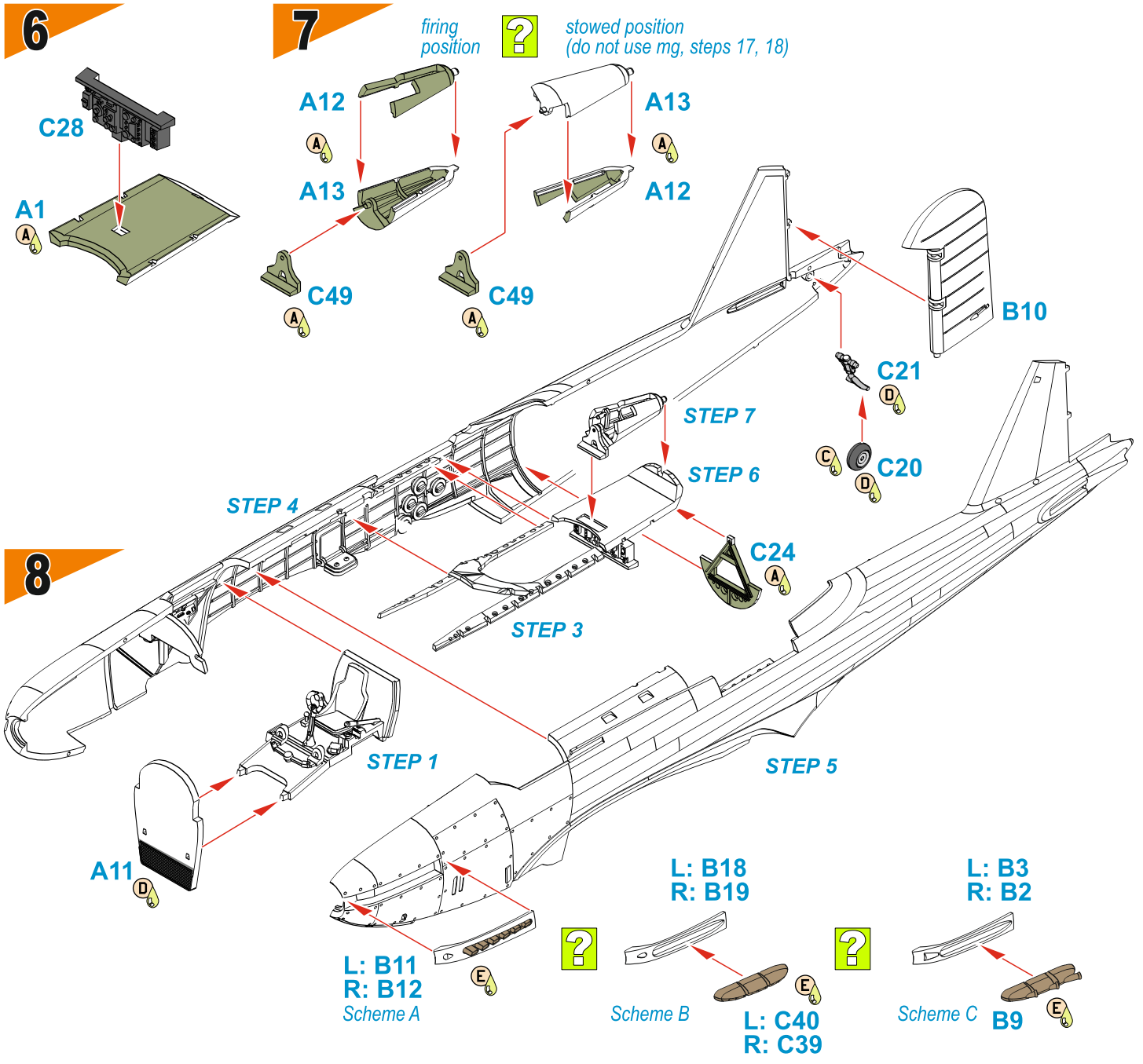

# 11

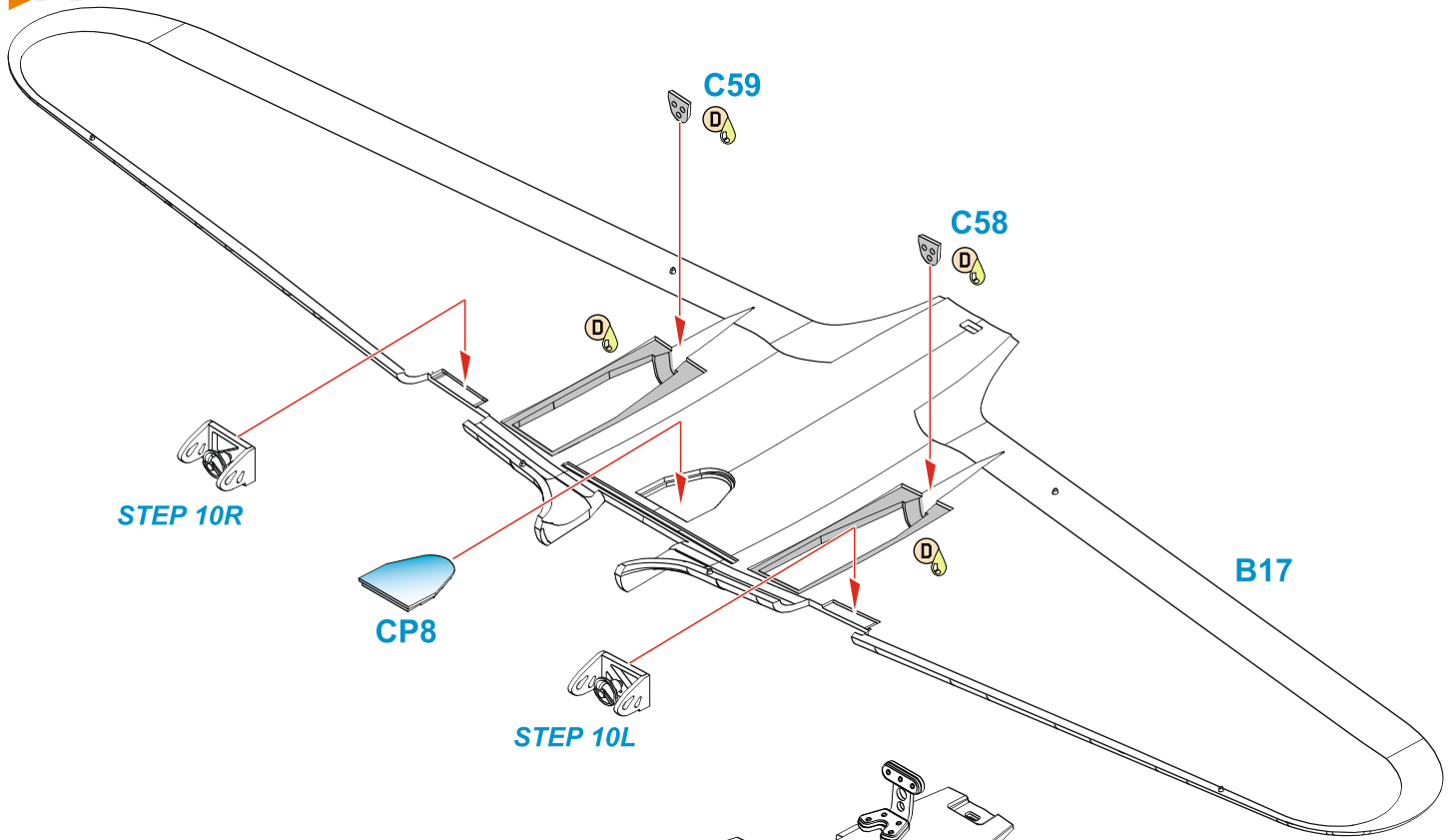

# 12

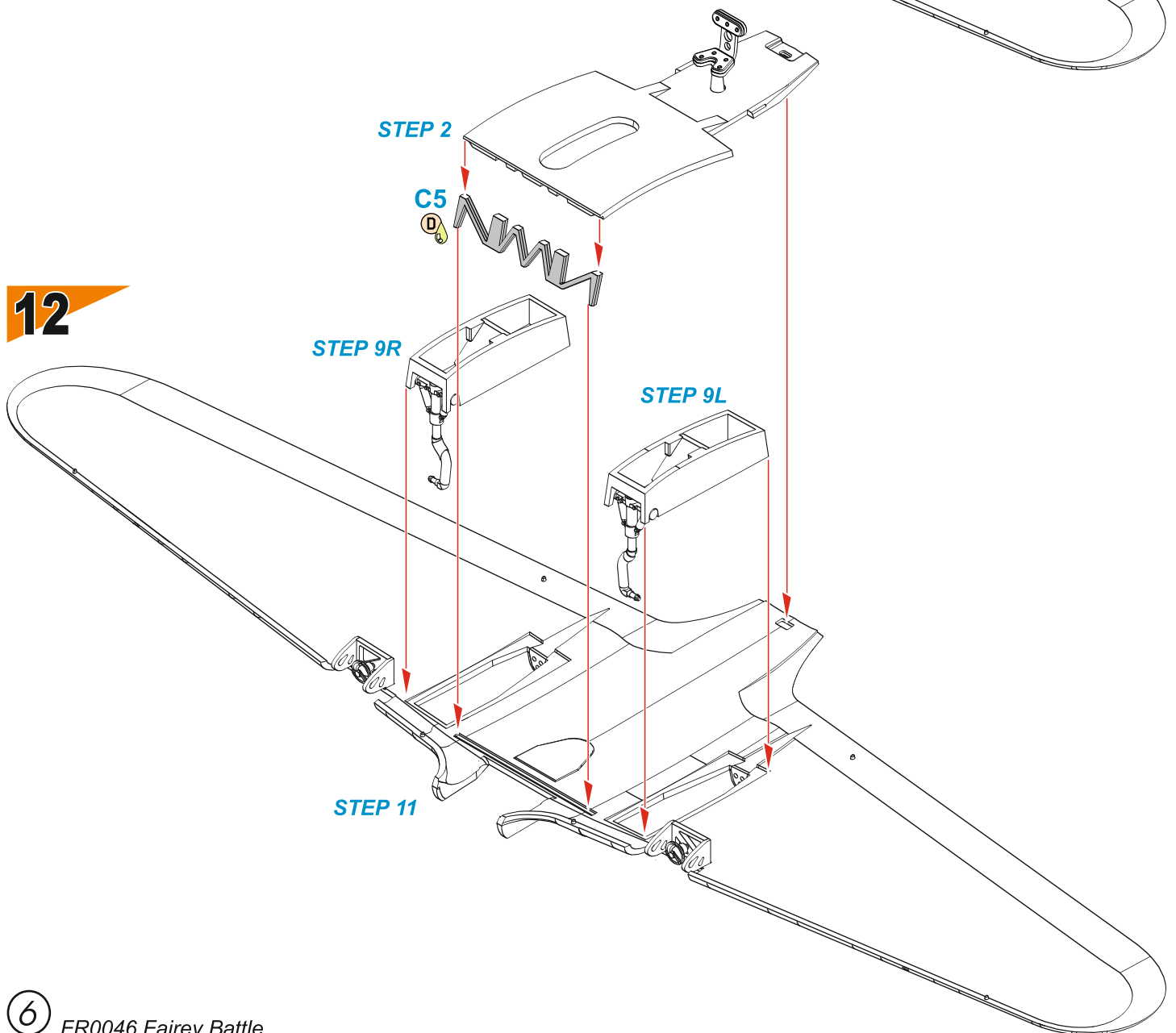

13

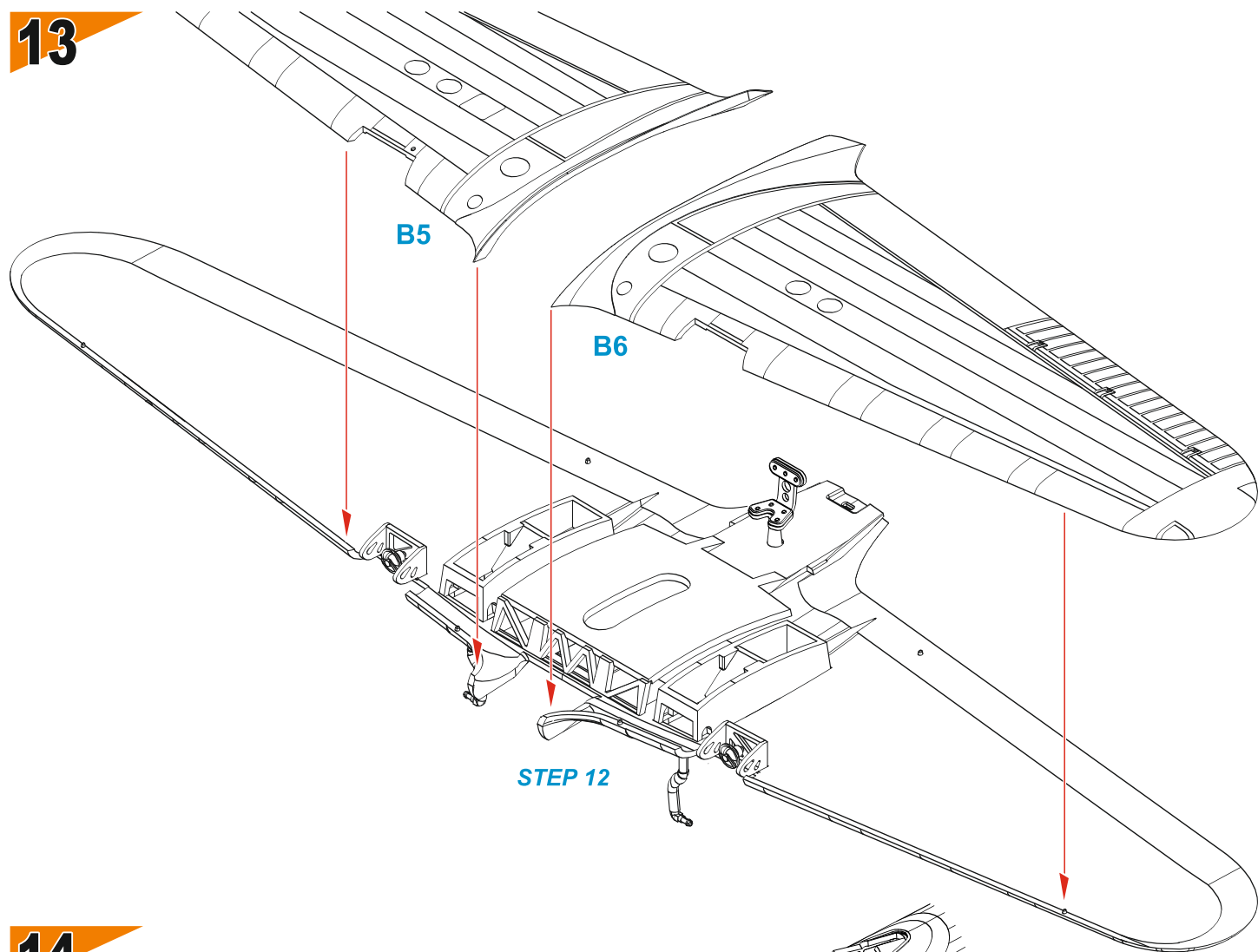

14

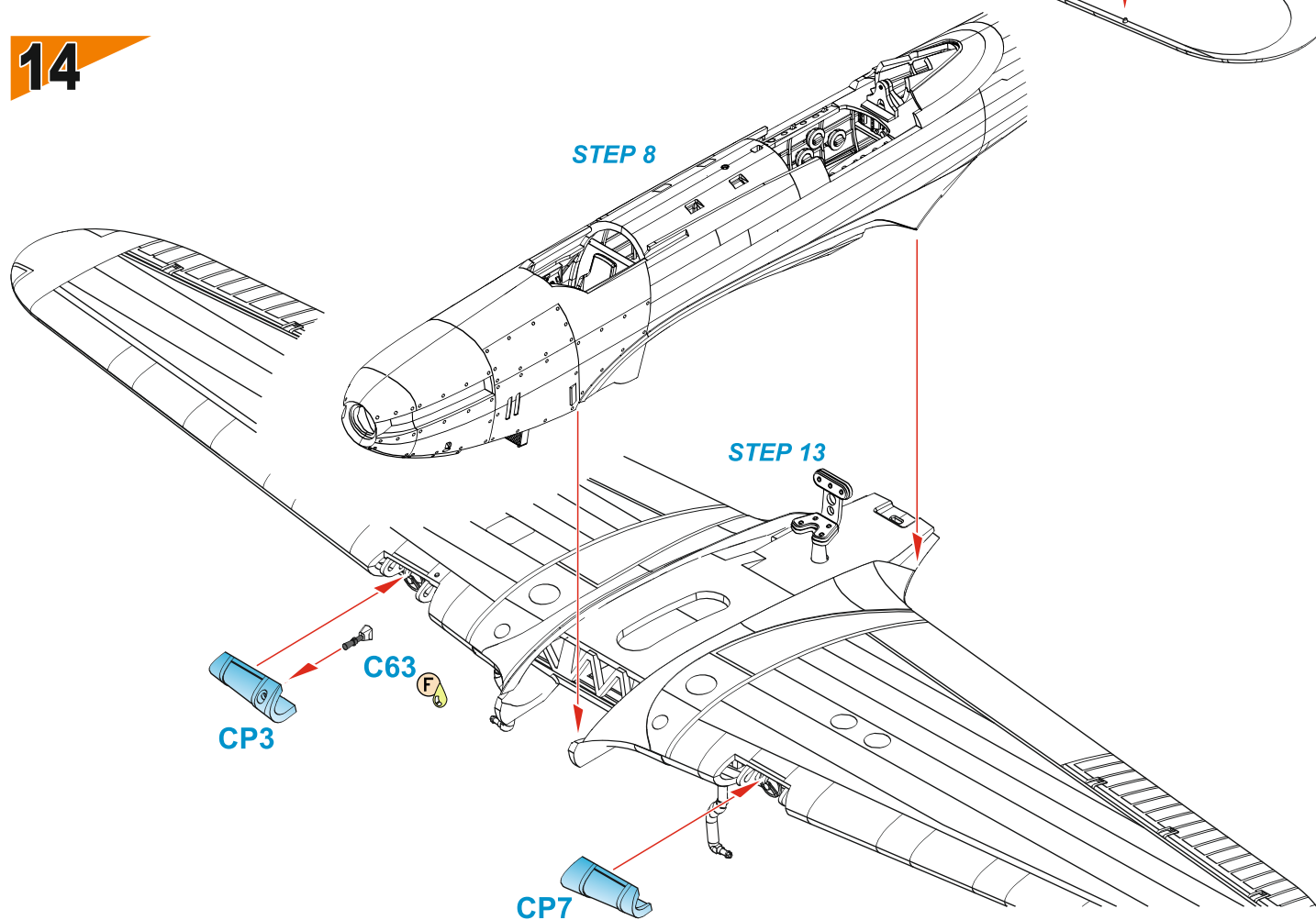

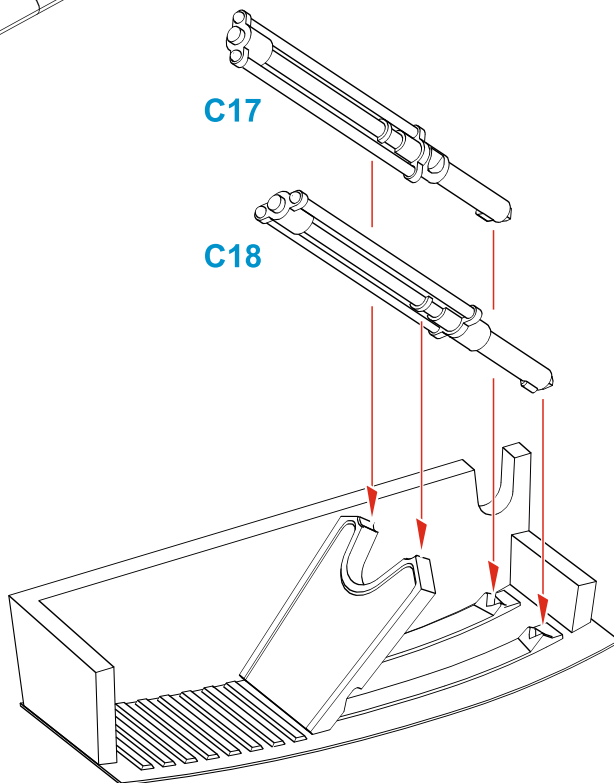
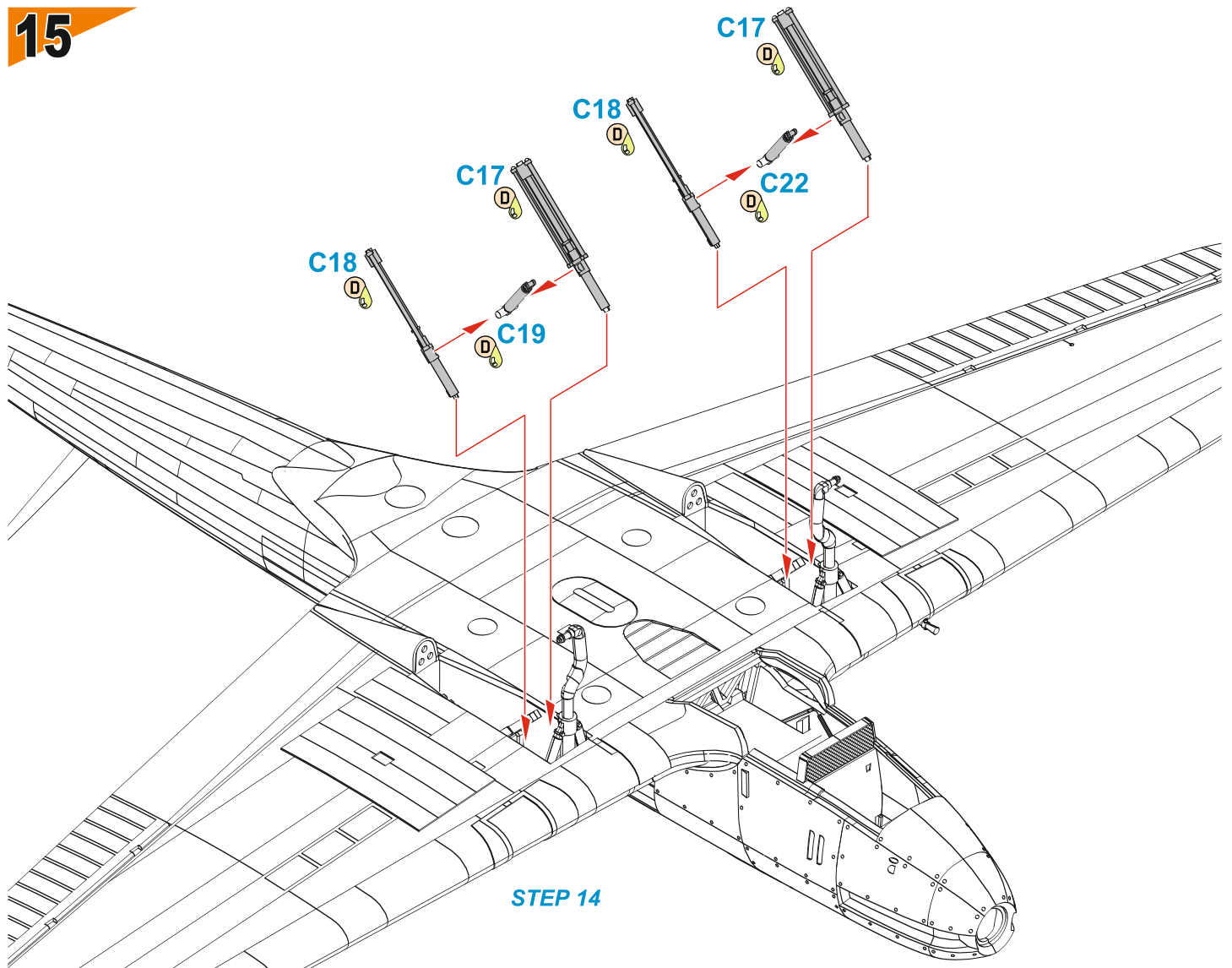

*undercarriage bay  
detail inside view  
rest of the airframe  
omitted for clarity*

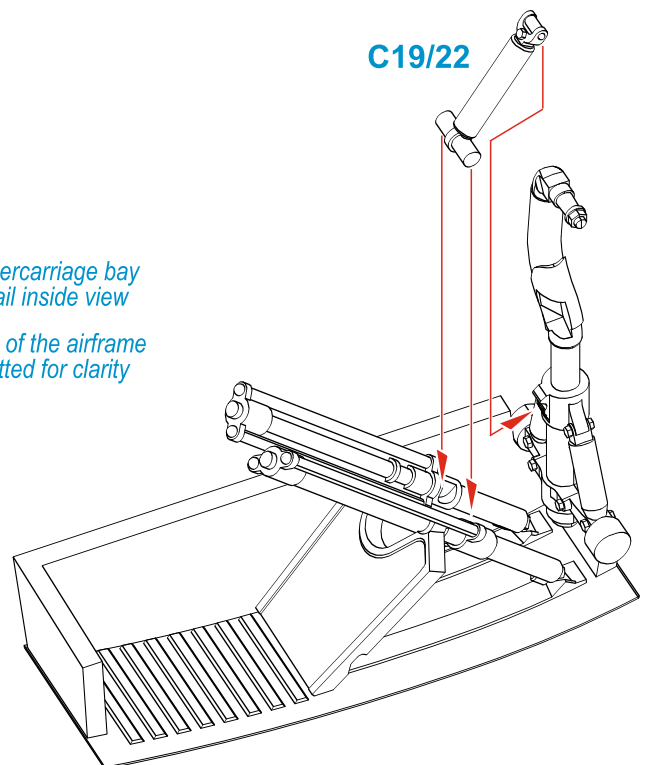



# 16

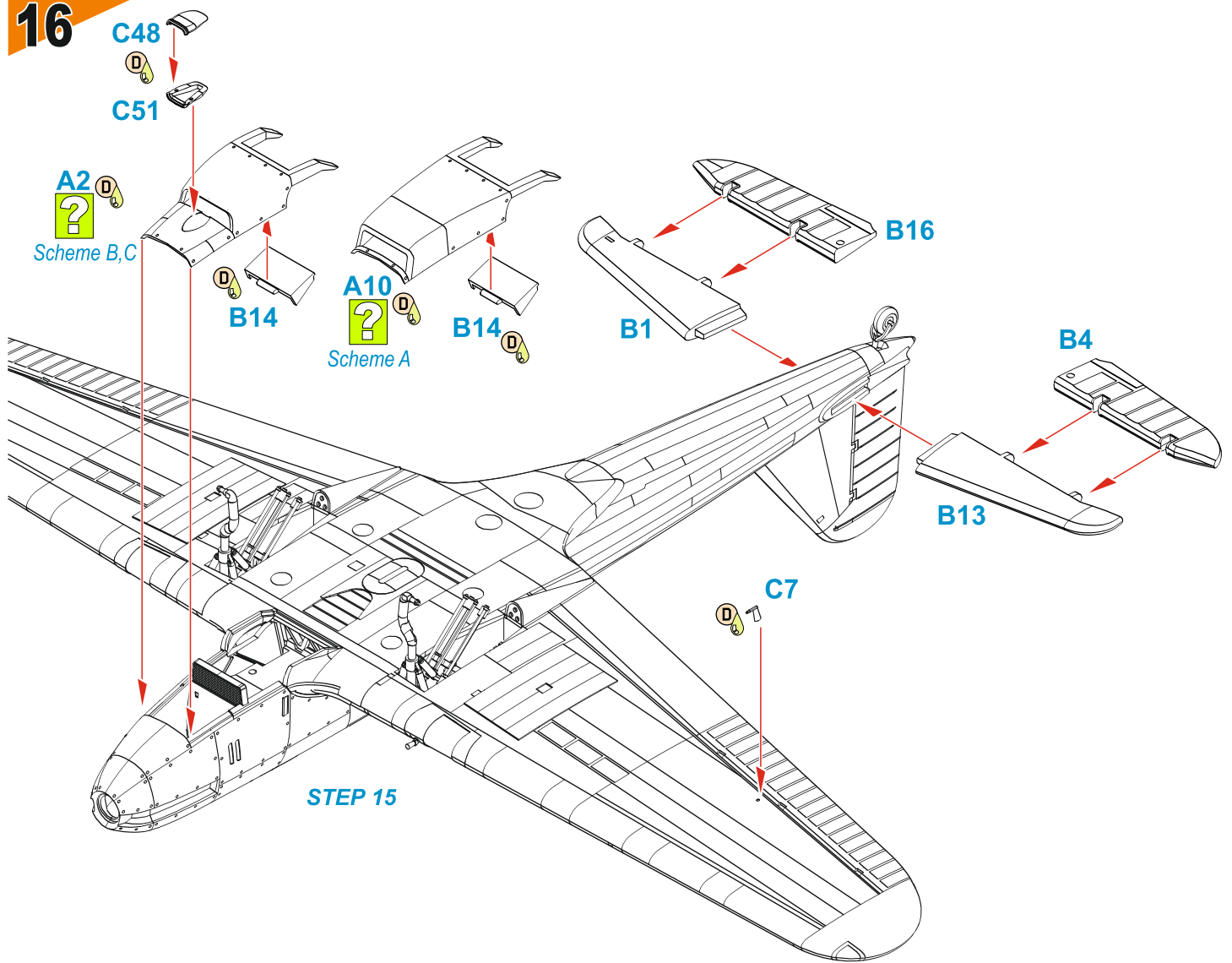

# 17

? Scheme A

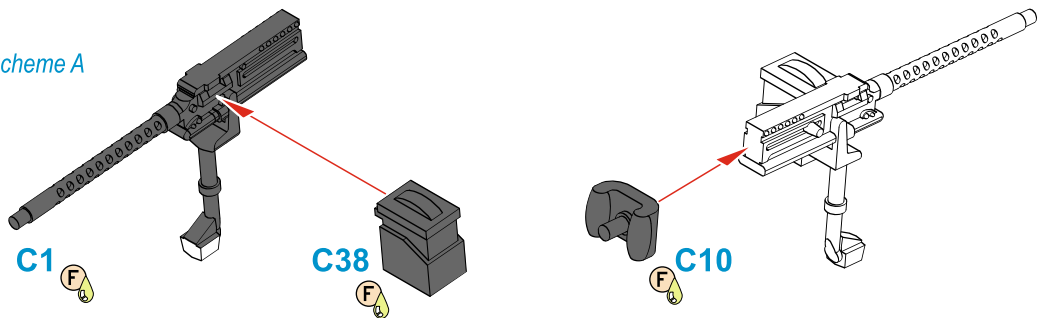

? Scheme B

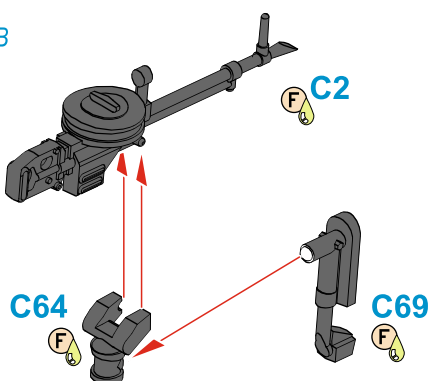

? Scheme C

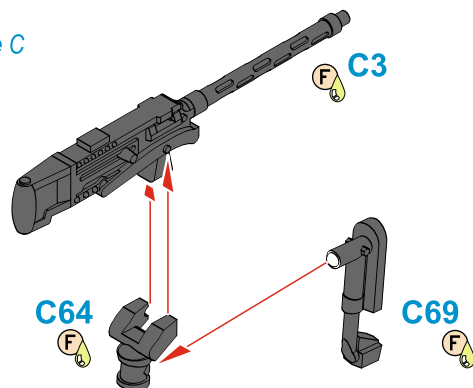

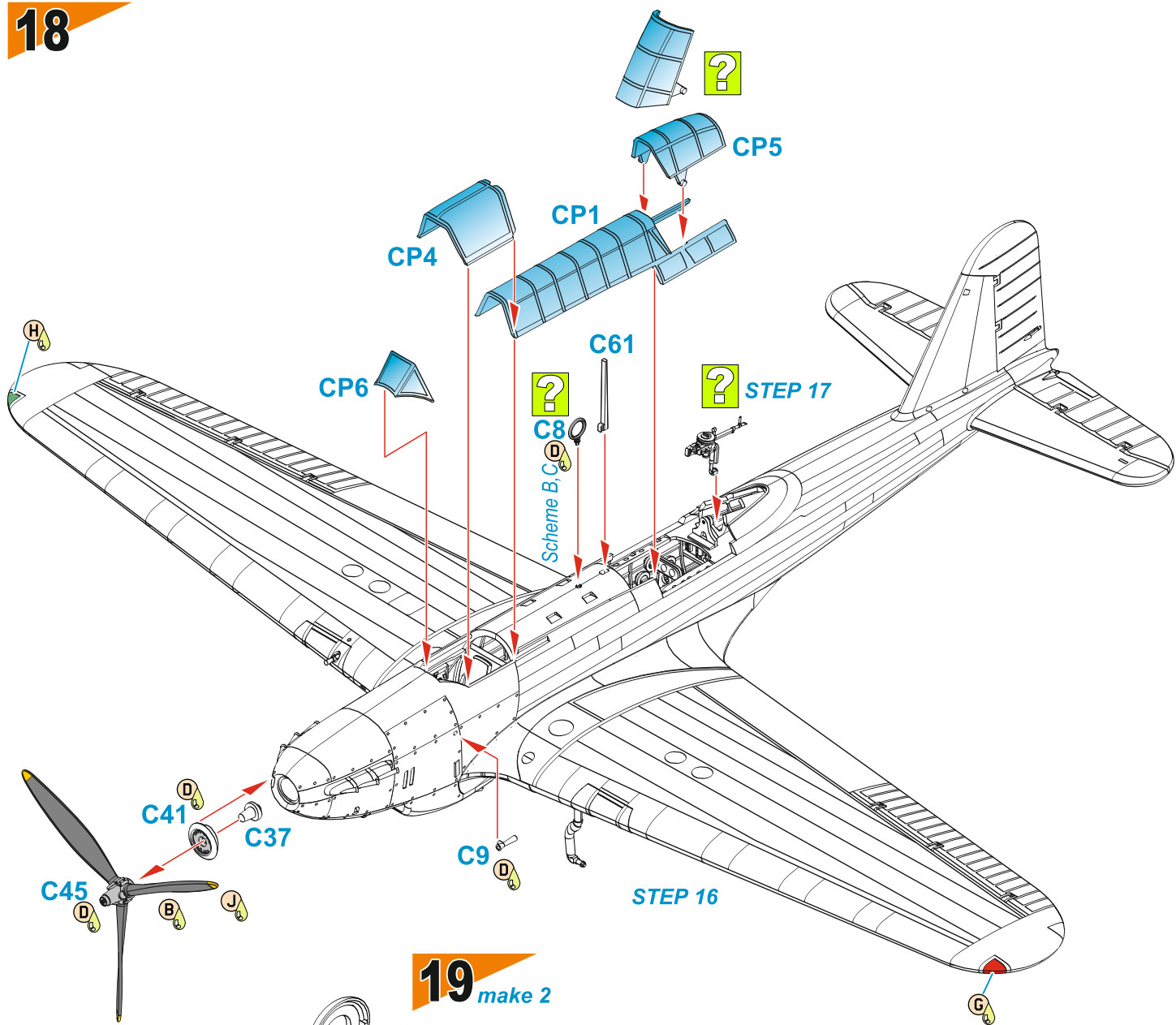

19 make 2

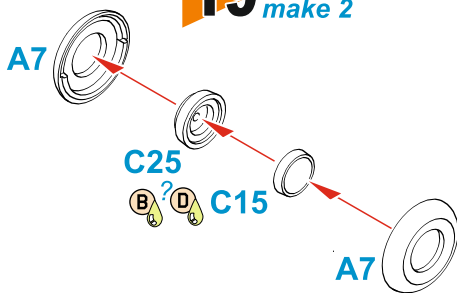

20

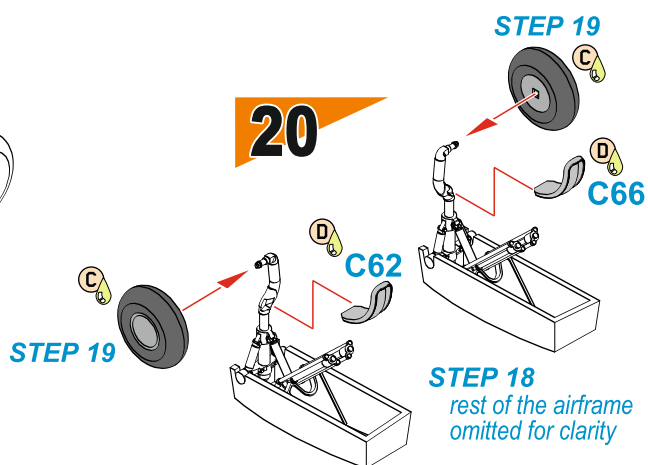

21

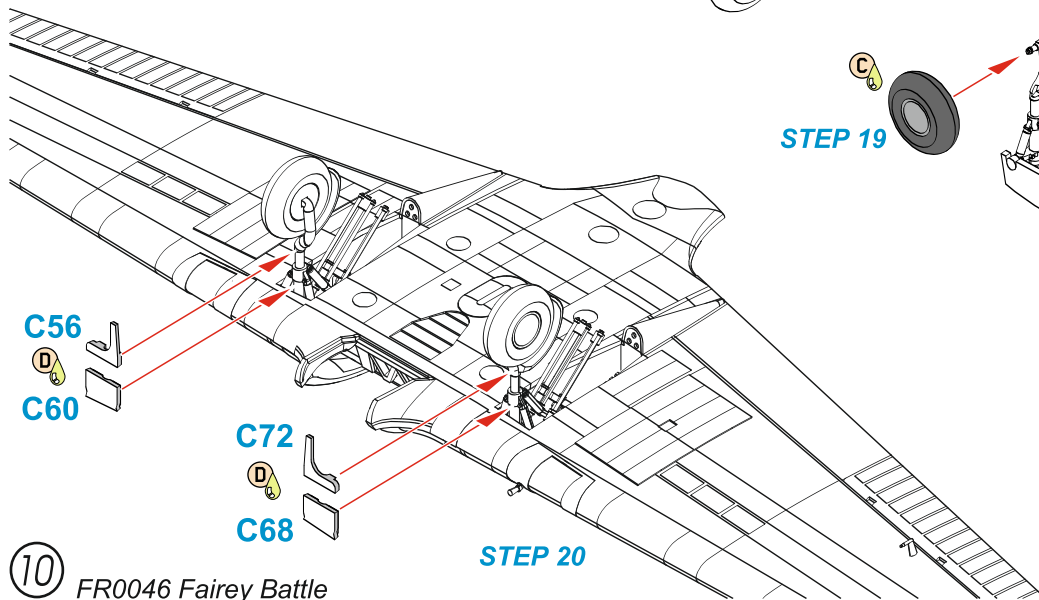

Battle Mk.I codé T70, III/3 Aé, Aeltre, Belgique, Cne Edmond Glorie, S/Lt Jean Vandenbosch. Attaque du pont de Vroenhoven, le 11 mai 1940.

Battle Mk.I coded T70, III/3 Aé, Aeltre, Belgium, Cne Edmond Glorie, S/Lt Jean Vandenbosh. Leading the bombing of Vroenhoven bridge, 11 May, 1940.

**Scheme A**

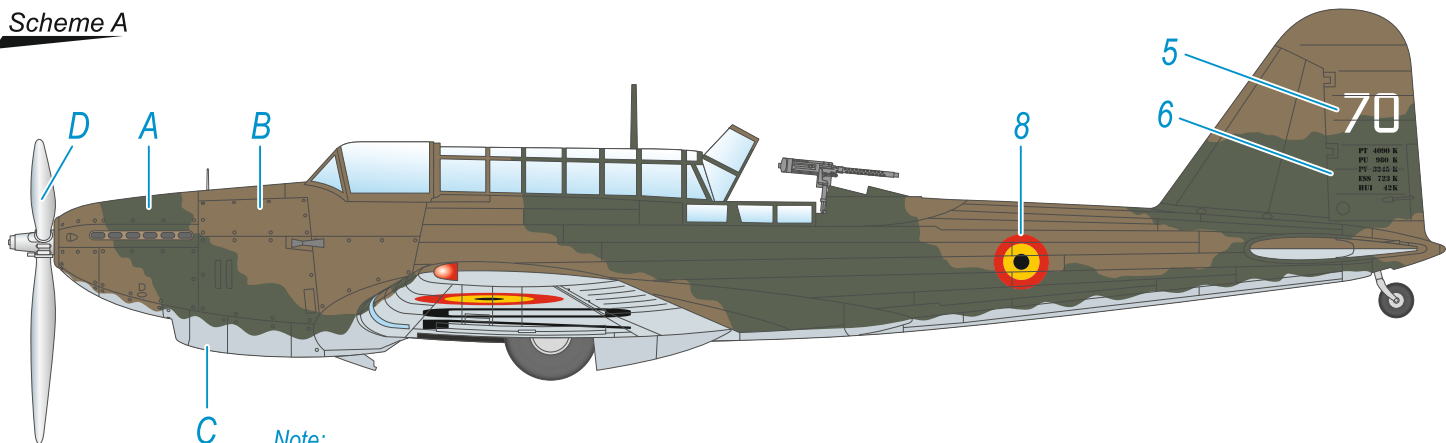

**Note:**  
 -séparation ondulée entre couleurs dessus et dessous  
 (y compris bord d'attaque des ailes)  
 -wavy separation between top and down colors,  
 including leading edge of wings

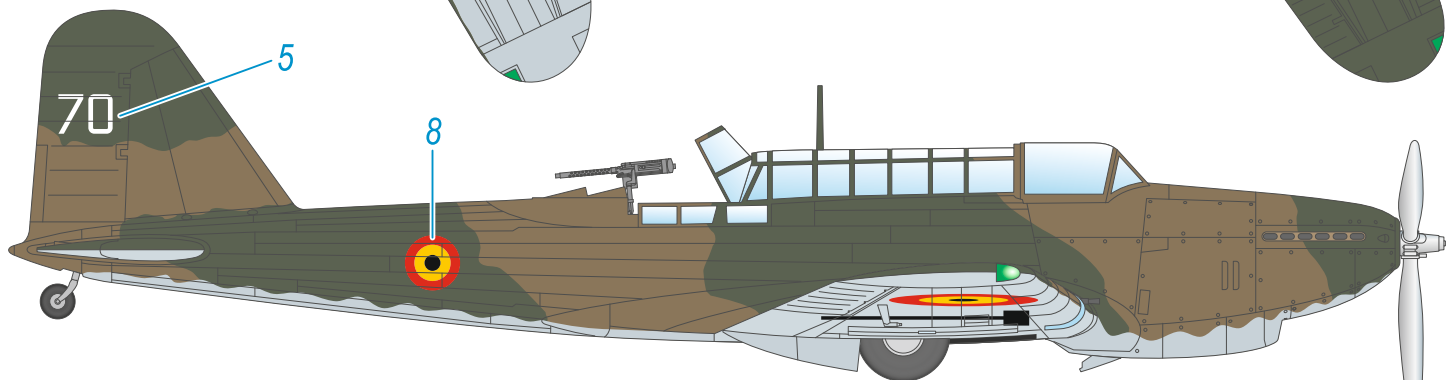
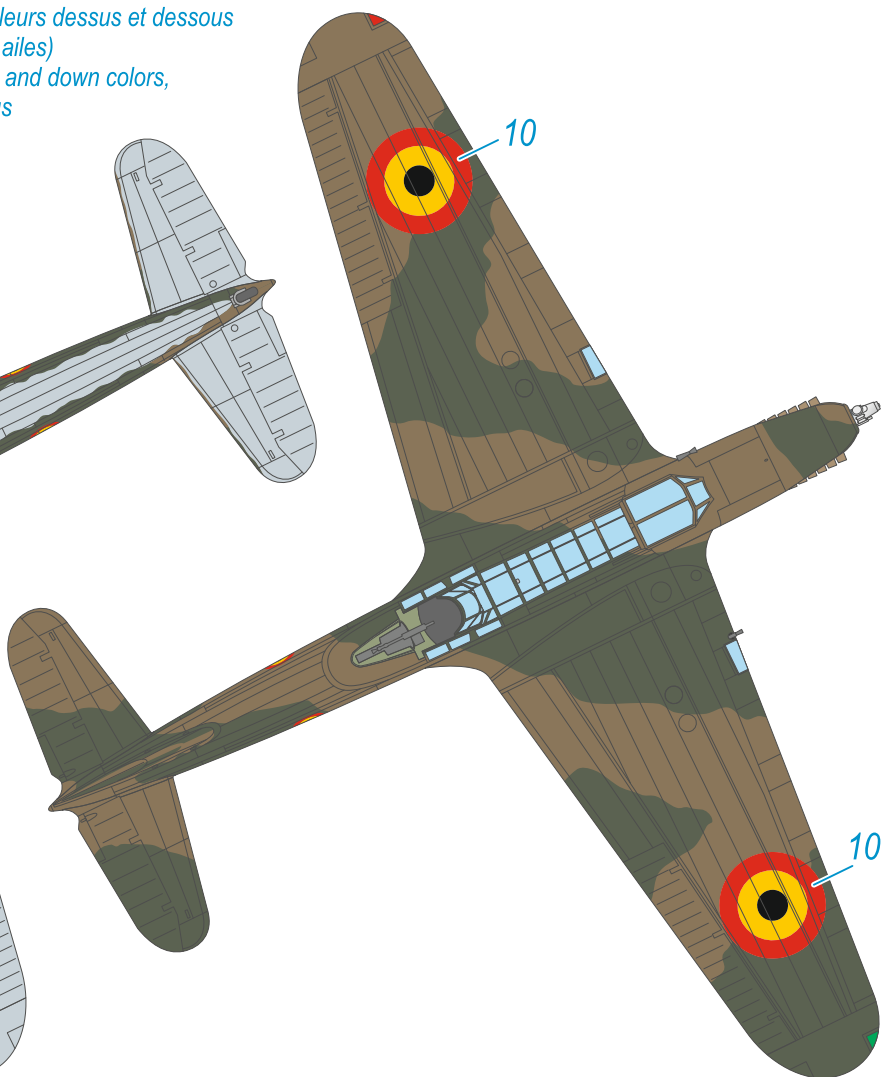
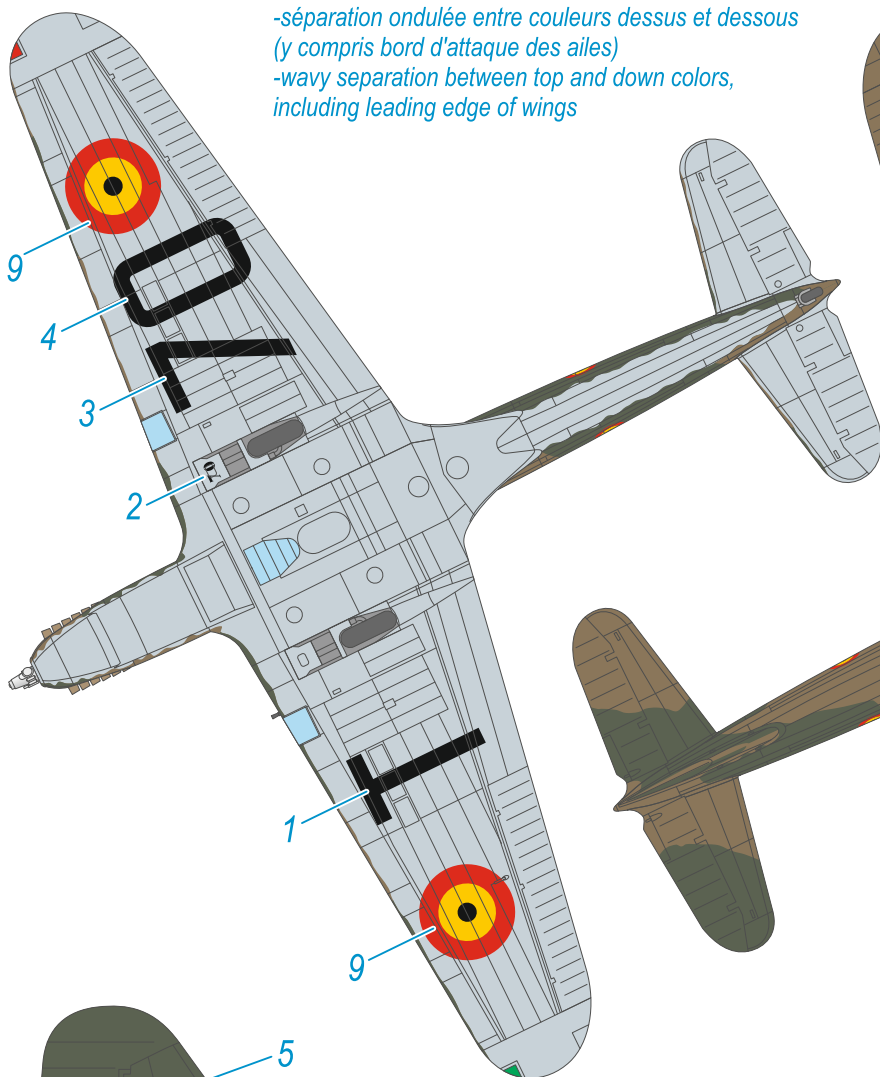

- |  |  |   |   |
|--|--|---|---|
| <b>A</b> Vert Foncé<br>Dark Green<br>H73/C23 | <b>B</b> Terre Foncée<br>Dark Earth<br>H72/C22 | <b>C</b> Aluminium Mat<br>Aluminium Dope<br>H8+11/C8+62 | <b>D</b> Aluminium<br>Aluminium<br>H/C8 |
|--|--|---|---|

Battle Mk.I K9264 PMoL de l'AASF, 103 Sqn RAF, 74 Wing, Challerange (Ardennes), France, mai / juin 1940

Battle Mk.I K9264 PMoL of Advanced Air Striking Force, 103 Sqn RAF, 74 Wing, Challerange (Ardennes), France, May / June 1940

*Scheme B*

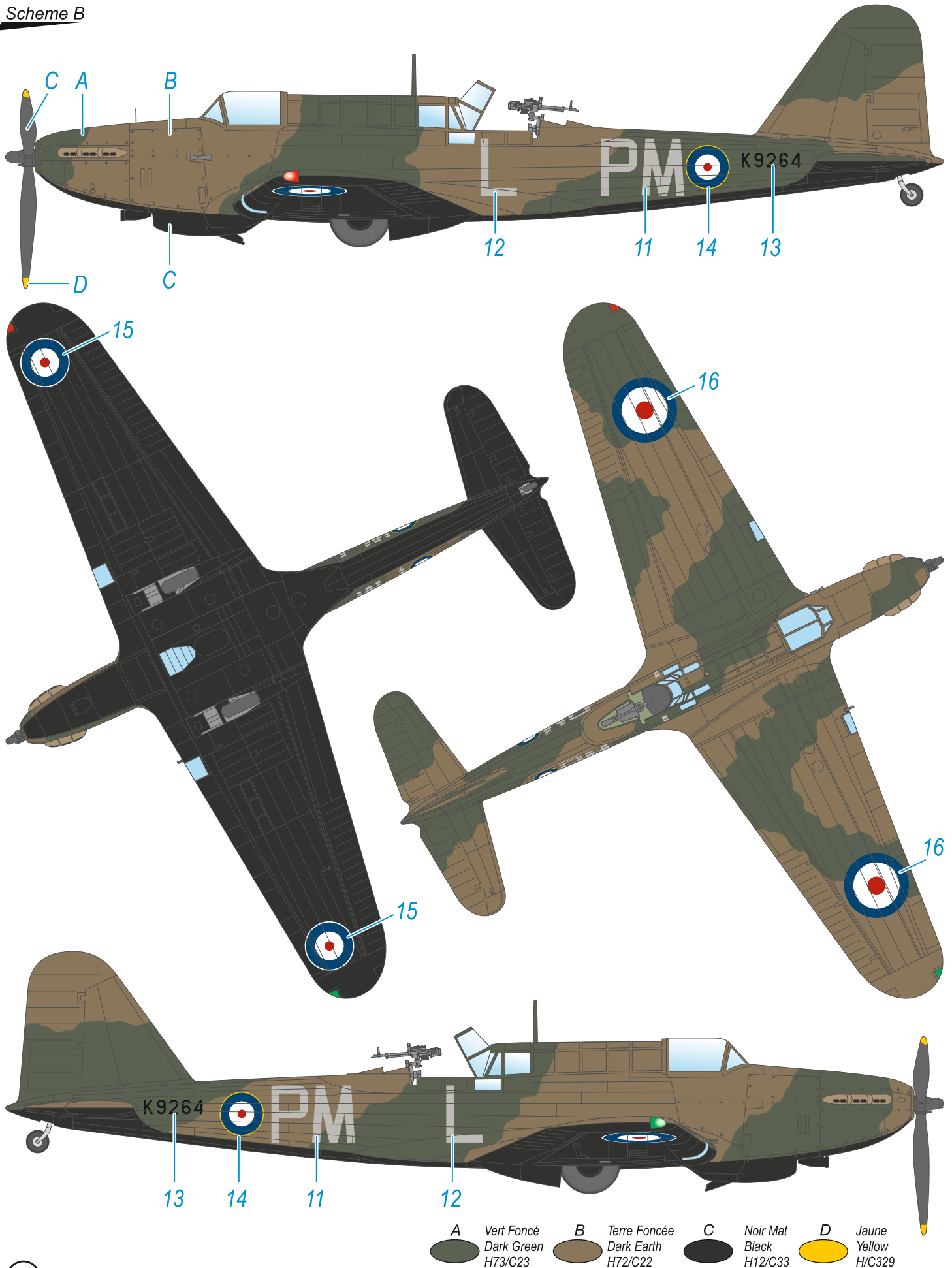

Battle Mk.I codé B274, Aviation Royale Hellénique, 33 Mira, Kouklaina, Macédoine Centrale, Grèce, à partir de février 1940. Cne Pitsikas et Lt Papas, appareil sévèrement endommagé en combat le 15 novembre 1940.

Battle Mk.I coded B274, RHAf, 33 Mira, Kouklaina, Central Macedonia, Greece, from February 1940. Captain Pitsikas and 2nd Lt Papas, aircraft severely damaged during a fight on 15 November, 1940.

*Scheme C*

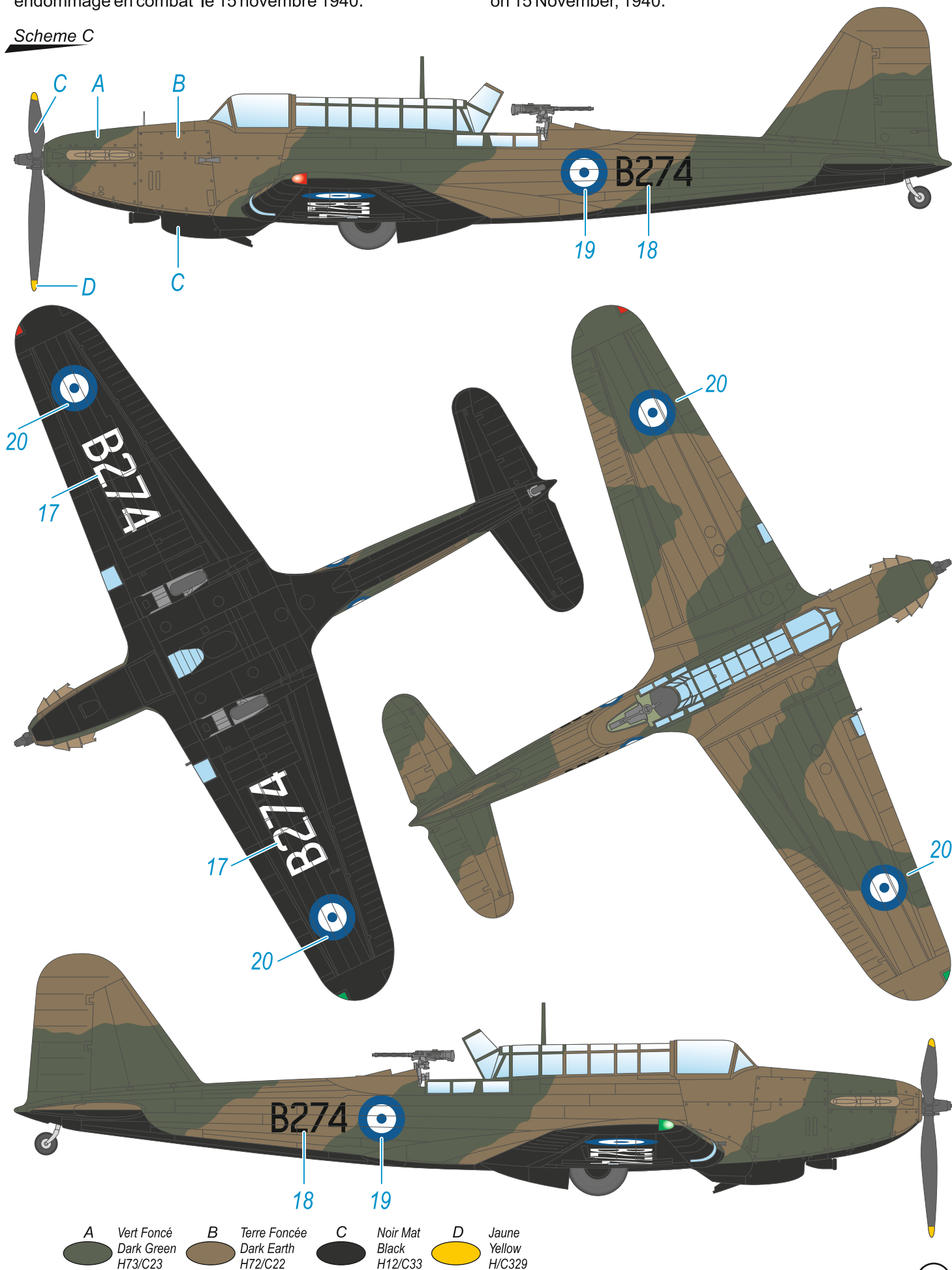

- |          |                                     |          |                                       |          |                              |          |                           |
|----------|-------------------------------------|----------|---------------------------------------|----------|------------------------------|----------|---------------------------|
| <b>A</b> | Vert Foncé<br>Dark Green<br>H73/C23 | <b>B</b> | Terre Foncée<br>Dark Earth<br>H72/C22 | <b>C</b> | Noir Mat<br>Black<br>H12/C33 | <b>D</b> | Jaune<br>Yellow<br>H/C329 |
|----------|-------------------------------------|----------|---------------------------------------|----------|------------------------------|----------|---------------------------|

# ATTRACTIVE 1/72 SCALE KITS

**FR0022**

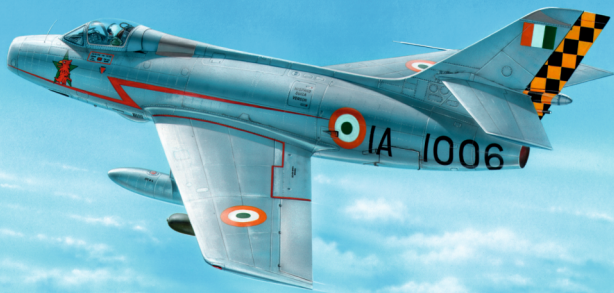

**Dassault Mystère IVA India**

**FR0023**



**PZL P.11f in Rumania**

**FR0027**



**Stampe S.V.4a Aerobatics**

**FR0034**



**Gamma 2E Bomber**

**FR0037**



**Potez 25 A2/B2 Lorraine**

**FR0038**



**Potez 25 A2/B2 Hispano**

**FR0039**



**Renard R-31 Belgium**

**FR0040**



**CASA C-212-300 France**

# ATTRACTIVE 1/72 SCALE KITS

**FR0049**



**SPAD 510 (7ème Escadre)**

**FR0050**



**SPAD 510 at war**

**FR0053**

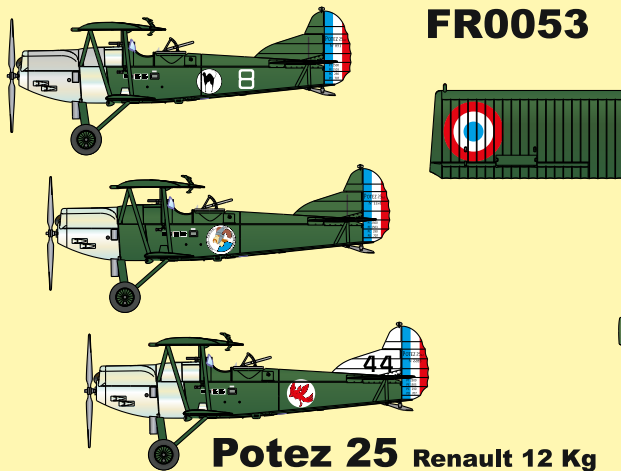

**Potez 25 Renault 12 Kg**

**FR0043**



**B-10B Export WC/WAN**

**FR0045**

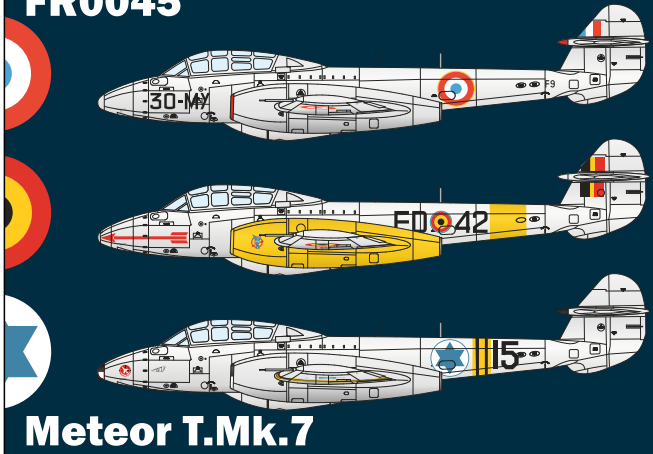

**Meteor T.Mk.7**

**FR0041**



**SNCASE S.E.535 Mistral**

**FR0031**



**Breguet 1050 Alizé 1G India**

**FR0052**



**DB-7 in French Service**

# ATTRACTIVE 1/72 SCALE KITS

**FR0055**



**Bloch MB.210 'Early'**

**FR0047**



**Fairey Battle Mk.I 'Poles in UK'**

**FR0048**



**Fairey Battle Mk.I 'AASF'**

**WWW.FRRROM.COM**